



NISSAN FRONT OUTER TIE RODS INSTALLATION INSTRUCTIONS:

1988-1994 NISSAN 180SX/240SX/SILVIA S13

1995-1998 NISSAN 200SX/240SX/SILVIA S14

1999-2002 NISSAN 200SX/SILVIA S15

1989-1994 NISSAN SKYLINE R32 (RWD ONLY)

1994-1998 NISSAN SKYLINE R33 (RWD ONLY)

1999-2002 NISSAN SKYLINE R34 (RWD ONLY)

PART NUMBER:

TINS-0100

We recommend that installation of all Voodoo13 parts be completed by a professional who is experienced in suspension tuning. With proper installation and maintenance, Voodoo13 suspension products will provide exceptional performance and durability. For any questions, please contact Voodoo13 immediately. We thank you for choosing Voodoo13 for your suspension tuning needs!

NEED HELP?

Our representatives are here to help you with any questions concerning the operation of this product.

CALL 480-889-0812

Monday thru Friday 8:30am to 5:30pm MST

RECOMMENDED TOOLS AND SUPPLIES

- General Mechanics Tool Set
- Jack and Jack Stands
- Sockets: 17mm, 19mm, and 15/16"
- Pliers and Mallet
- Torque Wrench

PART BREAKDOWN

NOTE: For any OE hardware please refer to OEM service manual for torque specifications. For all included hardware please torque to specifications shown below.

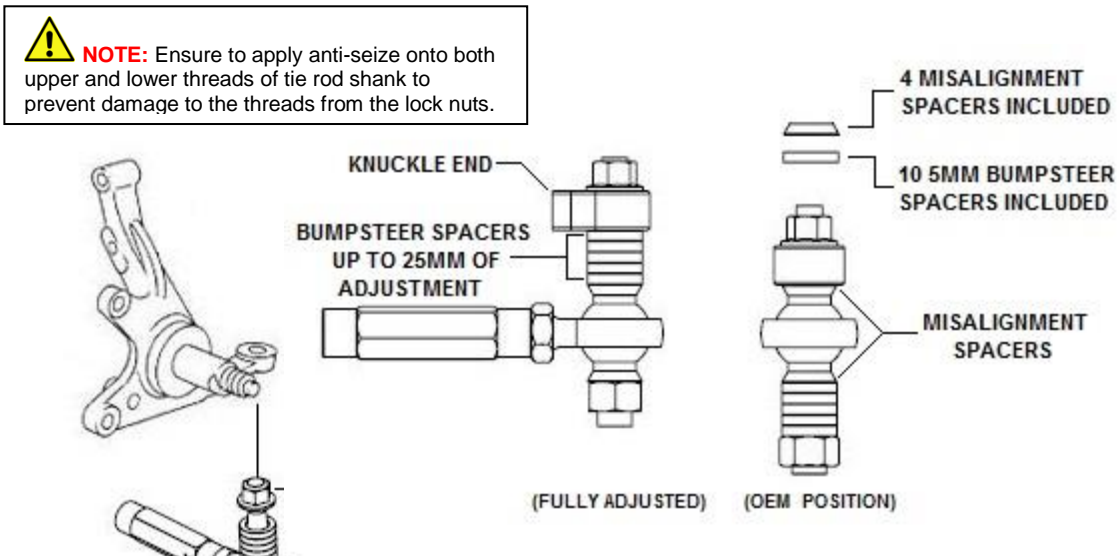

! NOTE: Ensure to apply anti-seize onto both upper and lower threads of tie rod shank to prevent damage to the threads from the lock nuts.

NOTE: With stock knuckles, use OEM Z32 or strengthen aftermarket Z33 inner tie rods. With modified knuckles, you may use S14/R32 inner tie rods however they may need to be shortened.

INSTALLATION PROCEDURE

Step 1: Lift the vehicle to a safe height using the recommended factory lift points to work underneath the rear suspension. Ensure to place safety jack stands where recommended by Nissan before anyone goes underneath the car (unless using a vehicle lift with safety locks).

Step 2: Remove lug nuts and front wheels from the vehicle.

Step 3: Loosen the jam nut securing the inner and outer tie rod together.

Step 4: Use pliers to remove the cotter pin from the outer tie rod.

Step 5: Remove the castle nut and then knock out the tie rod end.

Step 6: The outer tie rod can now be twisted off and replaced with the new inner tie rod. Ensure the jam nut is tight on the hex rod.

Step 7: Now slide the tie rod shank into the knuckle. Apply anti-seize to the upper shank threads, then torque the supplied 12mm lock nut to upper portion of the shank to 40 ft/lbs.

 **NOTE:** Ensure to apply anti-seize onto both upper and lower threads of tie rod shank to prevent damage to the threads from the lock nuts.

Step 8: From here decide the adjustment which will correct bumpsteer. Note that the lower control arm's position must be adjusted accordingly. Adjust the tie rods arms as parallel as possible to the front lower control arm to reduce bumpsteer.

Installation to achieve stock position of the OE outer tie rod, use the misalignment spacers provide.

Step 9: Once decided on adjustment for bumpsteer correction, slide the spacers up onto the shank and fit the heim end on to the shank. Follow the diagrams for reference. Apply anti-seize to the lower shank threads and torque the 5/8" lock nut on the bottom of the shank to 30 ft/lbs.

Step 10: Place wheels onto the vehicle and torque the lug nuts to factory specification via service manual.

Step 11: Lower vehicle safely back to the ground and perform a vehicle alignment. You are finished!

WARRANTY

All products sold are subject to the following warranty:

Voodoo 13 offers a Limited Lifetime Warranty for our products to the original retail consumer against defects and workmanship when used on light truck and car applications under normal operating conditions. This warranty does not apply to parts that have been improperly installed or wearable items such as, but not limited to, worn bushings or bearings unless proven to be defective from the manufacturer.

Exterior finish on all Voodoo 13 products is not considered a valid warranty; consumers are responsible for the maintenance of paint, anodize or raw metal finish.

The consumer will be responsible for the removal and freight costs both to and from the Distributor from which the product was originally purchased. Proof of purchase and product registration through the Voodoo 13 website is mandatory in order to receive warrantee replacement; original invoice from the Distributor from which the product was purchased must accompany the product in question for warrantee.

Voodoo 13 has the right to refuse a warrantee claim if procedures are not met by the original consumer. All returns must have an R.M.A. approval from Voodoo 13 prior to shipping direct to the Voodoo 13 facility. Exclusions from this warranty are sales outside of the United States, the finish, dents, rust, or any condition caused by abnormal use or neglect.

WARNING

High performance parts. For off-road use only. Installation should be carried out by a qualified facility. Improper use or installation may result in injury or death.



VOODOO13
254 W Charter Oak Rd
Mesa, AZ 85210
Ph: 480.889.0812
Fax: 480.829.8103
www.VOODOO13USA.com